

## Application Sheet

# How to Apply Honeywell APS00B Angular Position Sensor ICs

### 1.0 INTRODUCTION

Magnetic position sensing using Anisotropic Magnetoresistive (AMR) sensors is becoming a popular method of implementing a non-contacting location of motional objects. By affixing a magnet or sensor element to an angular or linear moving object with its complementary sensor or magnet stationary, the relative direction of the resulting magnetic field can be quantified electronically. By utilizing multiple sensors or magnets, the capability of extended angular or linear position measurements can be enhanced.

This application note explains the principles of AMR sensors for positional measurements, and includes several real-life circuit applications to solve engineering problems.

### 2.0 PRINCIPLES OF AMR SENSORS

Anisotropic magnetoresistance occurs in certain ferrous materials and can be applied as a thin strip to become a resistive element. Honeywell uses a ferrous material called Permalloy and forms four resistive elements to become a Wheatstone bridge sensor. Each magneto-resistive strip element possesses an ability to change resistance in a  $\cos^2 \theta$  relationship where  $\theta$  (theta) is the angle between the magnetic moment ( $\mathbf{M}$ ) vector and the current flow ( $\mathbf{I}$ ). Figure 1 shows the Permalloy element with field and current applied.

**Figure 1. AMR Element**

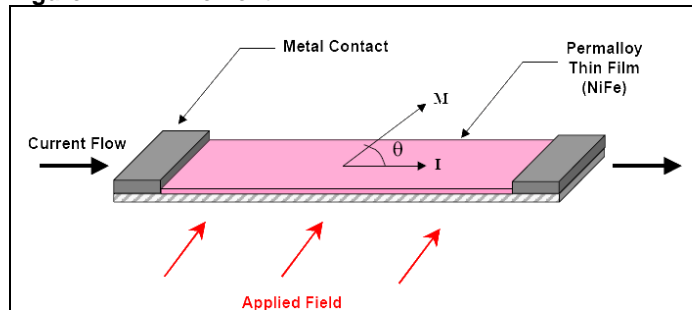

To create the sensor from the AMR elements, the four elements are oriented in a diamond shape with the ends connected together by metallization to form the Wheatstone bridge. Arbitrarily, the top and bottom connections of the four identical elements are given a Direct Current (DC) stimulus in the form of a supply voltage ( $V_s$ ), with the remaining side connections to be measured.

With no magnetic field supplied (0 Gauss), the side contacts should be at the same voltage, except for a small offset voltage due to manufacturing tolerances on the AMR elements. With the AMR elements connected in this fashion to form the Wheatstone bridge, these side contacts will produce a differential voltage ( $\Delta V$ ) as a function of the supply voltage, MR ratio, and the angle  $\theta$ , which is the angle between the element current flow and element magnetization ( $\mathbf{M}$ ). Figure 2 depicts this sensor bridge.

**Figure 2. AMR Bridge**

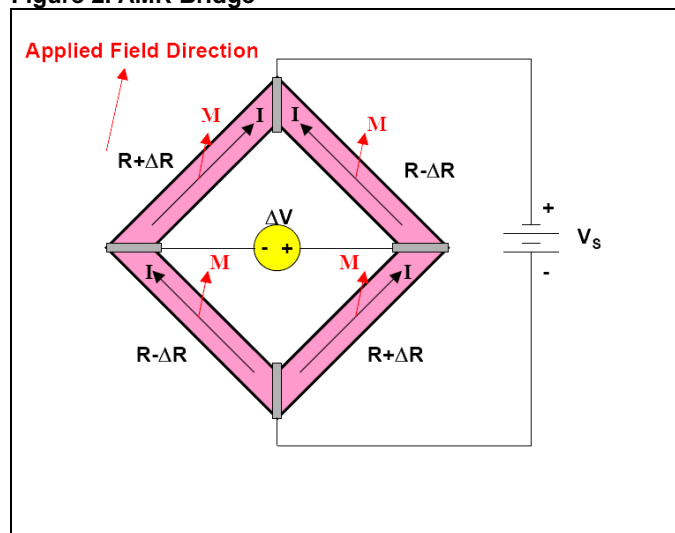

Lack of familiarity with the products, the applicable standards and conventions, as well as potentially complex wiring, can make product application intimidating.

To have the element magnetization direction align with an externally applied magnetic field, the applied field must "saturate" the permalloy material. As opposed to other AMR sensor elements that operate in a linear mode, position sensing is a saturation mode function, meaning that the external magnetic field completely re-orientates the material's magnetization.

For Honeywell's magnetic position sensors, a minimum of a 60 Gauss magnetic field must be applied at the bridge for the specified performance characteristics to be met. Fields less than 60 Gauss will show some bridge operation; however, the saturation may not be complete enough to be relied upon.

# How to Apply Honeywell APS00B Angular Position Sensor ICs

## 3.0 OUTPUT SIGNALS

The APS00B is Honeywell Sensing and Control's AMR-based magnetic position sensor that contain AMR sensor bridges to be used in saturation mode. The APS00B contains two AMR bridges for a  $\pm 90^\circ$  range of position sensing. With the bridges on the APS00B oriented  $45^\circ$  in rotation from each other, the differential output voltages for sensor bridges A and B are:

$$\Delta V_A = V_s S \sin(2\theta) \text{ and } \Delta V_B = V_s S \cos(2\theta), \text{ where:}$$

$V_s$  = Supply Voltage (V)

$S$  = Material Constant (11.5 mV/V)

$\theta$  = Reference to Magnetic Field Angle ( $^\circ$ )

Using the APS00B bridge A signal output plotted versus theta, Figure 3 depicts the two-cycle waveform.

Figure 3. Two Cycle Waveform

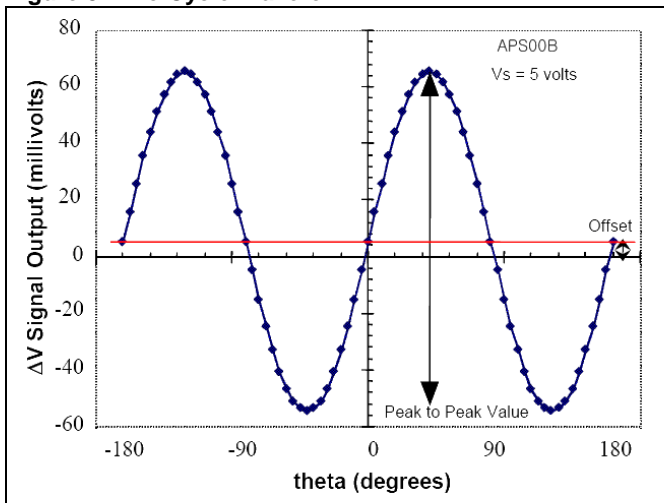

As seen in Figure 3, the most linear range for this sensor bridge is in the  $\pm 45^\circ$  range about the  $-180, -90, 0, 90,$  and  $180$  degree points. Of these, the  $0$  and  $-180$  points have a positive slope, and the  $\pm 90$  points have a negative slope. These slopes can be taken to full advantage for angular and linear positioning applications.

Now that a fairly accurate method for magnetic field direction sensing is established, it should be noted that some errors should be adjusted to enhance the accuracies of the measurements.

The first error is the offset error voltage as depicted in Figure 3 and mentioned earlier as a byproduct of manufacturing tolerances. To compensate for the offset, either analog signal processing or digital value corrections can be used. In the analog signal processing solution, an opposing error voltage can be summed into the bridge output signal via signal conditioning circuitry. In the digital solution, the digitized value of the output signal can be combined with an error correction value.

Another common error to be accounted for is the drift in the material constant versus temperature. This error affects both the bridge sensitivity and offset. Coefficients of temperature (tempcos) of the sensitivity and offset are nominally  $-0.32\%/^\circ\text{C}$  and  $-0.01\%/^\circ\text{C}$ , respectively. If the application has a large operating temperature range, temperature monitoring circuitry should be considered to produce error corrections to offset the temperature drift.

If multiple bridge sensors are used, a third error that should be compensated for is the part-to-part tolerance in material constant. This manifests itself as a change in sensitivity, resulting in varying peak-to-peak voltage swings in the  $\Delta V$  versus theta plots. Much like the offset error voltage, analog signal processing or digitized value corrections can be implemented to counter this sensitivity tolerance.

## 4.0 ANGULAR POSITION SENSING

For simple magnetic angular position sensing, the APS00B sensor can be used to detect the relative motion of a nearby magnet in angular displacement. Figure 4 shows a typical orientation.

Figure 4. Angular Position Sensing

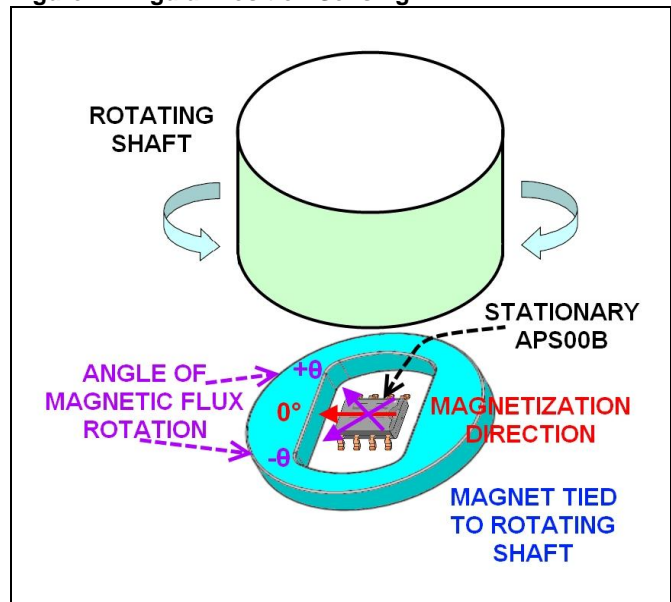

Given a typical supply voltage of 5 V ( $V_s = +5 \text{ Vdc}$ ), each bridge of the APS00B will provide approximately a 120 mV swing ( $\pm 60 \text{ mV}$ ) on 2.5 V bias voltage. The reason for the 2.5 V is that with the Wheatstone bridge supply voltages at 0 V and +5 V, the bridge performs a rail splitter function to create two near +2.5 V sources driven apart by  $\Delta V$  as created by the magnetic field and the offset error voltage. Figure 5 shows this transfer curve.

# How to Apply Honeywell APS00B Angular Position Sensor ICs

**Figure 5. Transfer Curve**

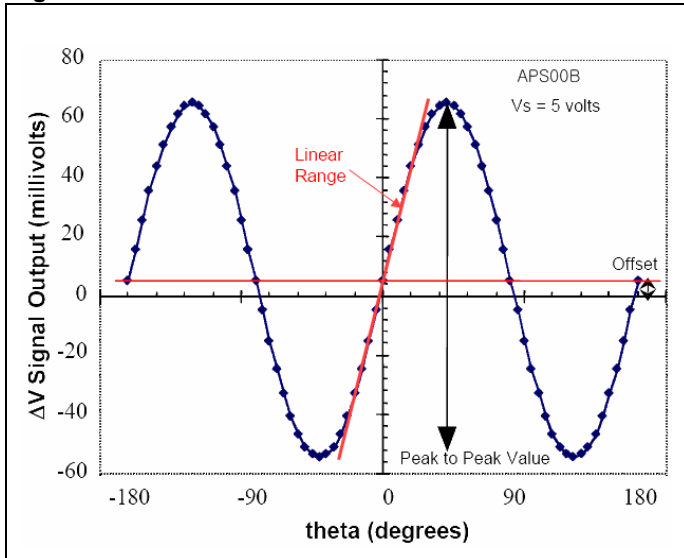

To interface with output pins of each bridge of the APS00B (OUT A+, OUT A-), an instrumentation amplifier circuit is typically used. Instrumentation amplifiers can be purchased as complete integrated circuits, or constructed via combinations of discrete components and integrated circuits such as operational amplifiers (op-amps). The purpose of an instrumentation amplifier is to derive the difference signal (OUT A+ minus OUT A-), and to provide additional signal amplification as desired. Figure 6 shows a typical instrumentation amplifier circuit using an op-amp with external discrete components. Honeywell APS00A instrumentation amplifier is designed and optimized to provide the best possible performance from the APS00B dual bridge sensor.

**Figure 6. Instrumentation Amplifier**

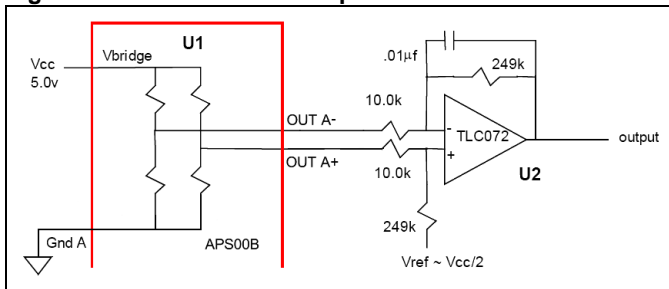

With a nominal 120 mV peak-to-peak signal swing at the bridge outputs, the above circuit schematic shows an instrumentation amplifier with a voltage gain of about 25. This will permit an output voltage swing of about 3 V peak-to-peak centered up on about 2.5 V (1 V to 4 V). Since the bridge offset specification is  $\pm 1\text{mV/V}$ , a 5 V supply applied to the bridge yields  $\pm 5\text{mV}$ . After the instrumentation amplifier gain, this offset is  $\pm 125\text{mV}$  which will stay within the power supply rails when combined with the amplified signal.

One method of countering the offset error voltage at the bridge is to change the value of Vref at the instrumentation amplifier from 2.5 V to a nearby voltage so that the amplifier output voltage remains at 2.5 V at each 90° rotation in field direction. This can be done using a trimming potentiometer (pot) with the wiper to Vref and the end positions of the potentiometer towards each supply rail. Figure 7 shows this method.

**Figure 7. Offset Trimming**

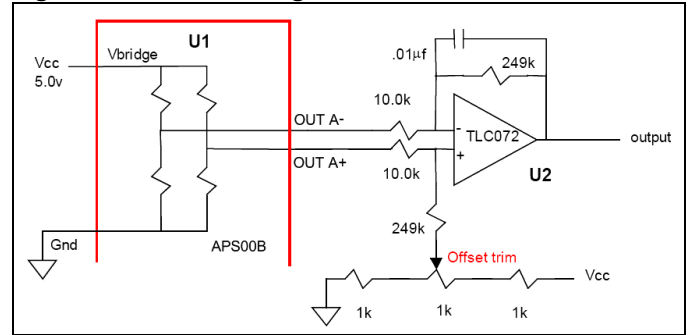

Another method of offset error voltage compensation is to measure it at production test and subtract that value from all future measurements. The advantages of this method is that the circuit component count remains minimal (like Figure 6), and no trimming procedure is required. The disadvantage is that you may have to reduce the amplifier gain to account for all the error buildup in offset and sensitivity tolerances, plus tempco changes that are all multiplied by the amplifier gain.

From Figure 8, as the shaft rotates around, magnetic flux from a magnet placed at the end of the shaft exits the north pole and returns to the south pole. With an APS00B placed on the shaft axis, the flux passing through the sensor bridges will retain the orientation of the magnet. From this rotation, the output of the two bridges will create sine and cosine waveforms as shown in Figure 9.

**Figure 8. Angular Position Sensing**

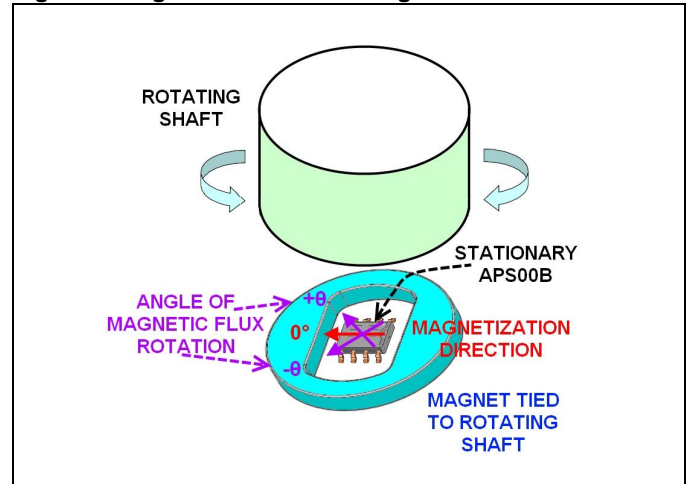

# How to Apply Honeywell APS00B Angular Position Sensor ICs

Figure 9. Sine, Cosine Waveforms

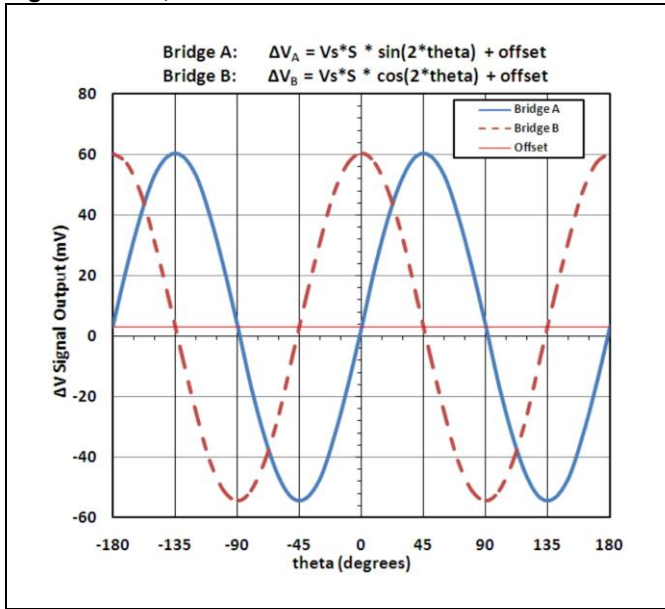

To extract the sine (sensor bridge A) and cosine (sensor bridge B), the offset error voltage must be eliminated. Then the ratio of Bridge A output to bridge B output creates a tangent  $2\theta$  function where the scaling factors ( $V_s * S$ ) cancel. Thus the angle theta ( $\theta$ ) is described as:

$$\theta = 0.5 * \arctan (\Delta V_a / \Delta V_b)$$

However, because there are some trigonometric nuances with the arctangent function when  $\theta$  gets close to  $\pm 45^\circ$  and beyond, these special cases apply:

For  $\Delta V_a = 0$ ,  $\theta = 0^\circ$

For  $\Delta V_b = 0$  and  $\Delta V_a < 0$ ,  $\theta = -45^\circ$

For  $\Delta V_b = 0$  and  $\Delta V_a > 0$ ,  $\theta = +45^\circ$

For  $\Delta V_a < 0$  and  $\Delta V_b < 0$ , subtract  $90^\circ$  from  $\theta$

For  $\Delta V_a > 0$  and  $\Delta V_b < 0$ , add  $90^\circ$  from  $\theta$

Because most trigonometric functions are performed as memory maps in microcontroller integrated circuits, these types of special conditions are easily dealt with. The resultant angle  $\theta$  is the relative position of the magnetic field with respect to the sensor. It should be noted that if rotation is permitted beyond  $\pm 90^\circ$ , the theta calculation will replicate again with positive and negative  $90^\circ$  readings jumping at the end points. Further performance to  $360^\circ$  or  $\pm 180^\circ$  can be mapped into a microcontroller by using this circuit plus a Hall-effect sensor to determine which side of the shaft is being positionally measured via magnetic polarity detection. Figure 10 shows the basic circuit interface for the APS00B.

Figure 10. APS00B Basic Circuit

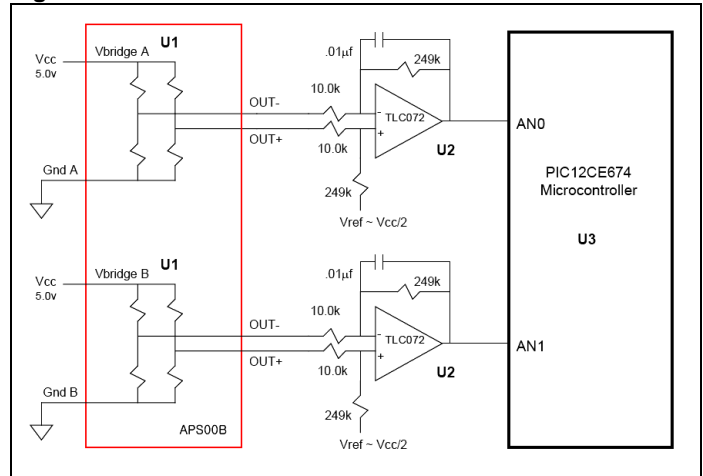

## 5.0 MOTOR SHAFT POSITION SENSING

Not all motors have the convenience of having the end of a shaft available for magnet placement. For those applications where the magnets must be placed along the circumference of the shaft, several approaches are available. The “wider position sensing” section covers the sensor at the end of the shaft, but two APS00B could be positioned  $180^\circ$  on each side of the shaft with a split magnet located above or below the sensors to come close to the end position sensing.

## 6.0 60 DEGREE ROTATION SENSING

To create a full  $360^\circ$  rotational position sensing solution, the APS00B sensor can be combined with a Hall-effect sensor. Most Hall-effect sensors use silicon semiconducting materials to create a proportional voltage output as a magnetic field vector slices orthogonally through the slab material with a bias current flowing through it. Figure 11 shows this principle.

Figure 11. Hall Effect

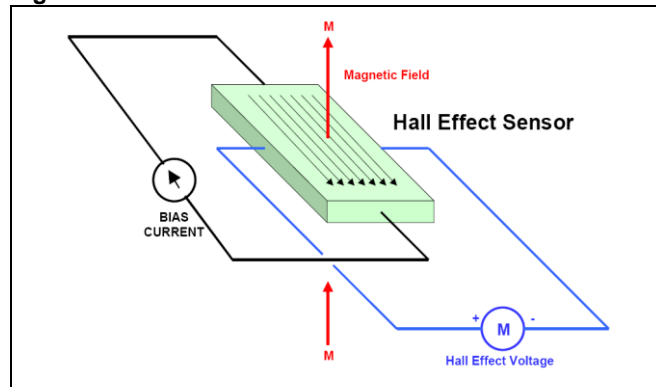

Although Hall-effect sensors do not offer the sensitivity or precision needed for accurate position sensing, they are used for  $360^\circ$  position sensing as “polarity” detectors to determine which half of the APS00B’s rotation a magnet is in. Figures 12 and 13 show a typical orientation and resulting waveforms for  $360^\circ$  position sensing.

# How to Apply Honeywell APS00B Angular Position Sensor ICs

Figure 12. 360° Position Sensing

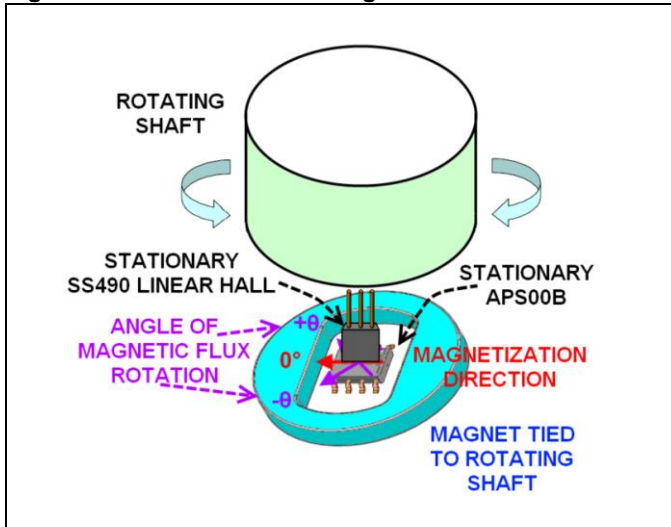

As the magnetic flux rotates about the APS00B and the Hall-effect sensor, the Hall-effect sensor's voltage will reverse its polarity at the flux vector changes from back-to-front to front-to-back through the silicon slab.

Figure 13. 360° Sensing Waveform

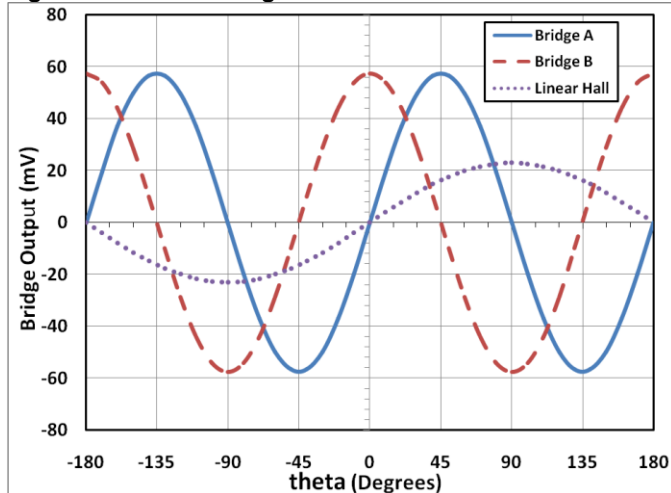

By placing a comparator on the Hall-effect sensor analog output, a digital representation of half rotation polarity is achieved. When combined with  $\pm 90^\circ$  sensing circuits of the APS00B, the sensing range is doubled, providing a complete  $\pm 180^\circ$  or 360° rotational sensor of high accuracy. One note is to mechanically ensure that the Hall sensor is nearly perfectly orientated with respect to the APS00B so that the arctangent equation deriving the heading arrives at the end positions just as the Hall sensor output achieves a zero volt output (patent pending).

Figure 14. Simplified 360° Sensing Circuit Diagram

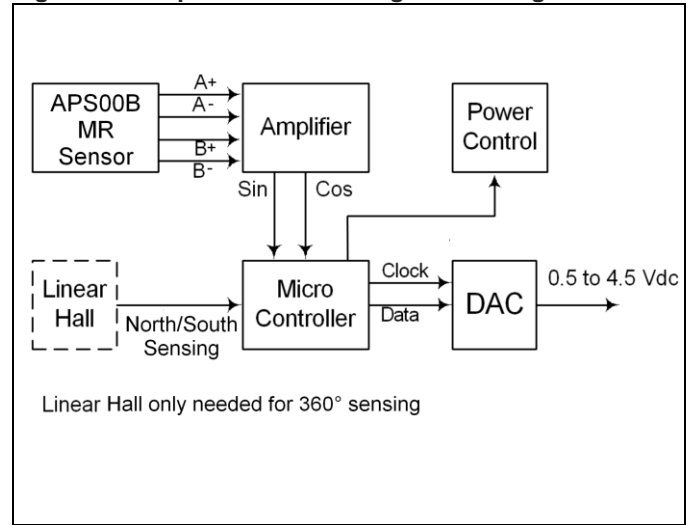

Linear Hall only needed for 360° sensing

## 7.0 KEY SENSOR SPECIFICATIONS

In choosing appropriate interface circuitry to sensor bridges, certain key specifications should be emphasized. The first specification to be noted is the bridge resistance. Each APS00B bridge has a resistance of 2500 Ohm, nominal. The two bridges are in parallel, producing a resistance of 1,250 Ohm, an important value to interface with the user's electronic circuitry and optimize it for power or noise performance. If minimum power consumption is of primary importance, the user has the option of gating or "duty cycling" the sensor bridge power supply to lower the total energy demand. If low noise performance is the utmost criteria, then the low bridge resistance of the APS00B favors lower noise voltages.

Bridge sensitivity is another key specification that should be examined by users. The APS00B sensors exhibit a nominal  $\pm 2.1$  mV per degree sensitivity in their most linear regions of performance around the zero crossing (output voltage). Given a nominal 115 mV output voltage ( $2 \times 57.5$  mV) and sub-micro-Volt noise floors, angular resolutions better than a few tenths of a degree can be achieved. By choosing the right signal conditioning bandwidth and the amount of effective bits of analog-to-digital converter resolution, the user can play into the strengths of these AMR sensors.

Another key specification is the bandwidth of the sensor bridge. While the APS00B promises up to 5 MHz of bandwidth, careful attention to magnetic and electronic design practices must be paid when sensing position at high shaft speeds. Particular emphasis should be made to keep bridge to signal conditioning layouts tight to minimize stray capacitance that may eat up precious system bandwidth. This becomes very critical when using multipole magnets in angular rotation.

# How to Apply Honeywell APS00B Angular Position Sensor ICs

## 8.0 THE HUMAN RESPONSE

When working with position sensing that interacts with human manual inputs, note that there is a minimum latency that can be tolerated when eye-hand coordination is desired. This typically is perceived as 20 position updates per second, or about 50 ms per update. When allocating time for analog-to-digital conversion, ensure extra time for computation and display settling times. This is especially true when using liquid crystal displays in cooler environments.

## 9.0 THE AMR VALUE PROPOSITION

The use of Anisotropic Magnetoresistive sensors provides a contactless method of achieving angular or linear position sensing. Unlike Hall-effect devices that require kilo-Gauss level magnetic fields from rare earth magnets, the APS00B provides a higher resolution sensor with much less field strength. The dominant limiting factor on resolution is typically the analog to digital converter bit size over the Boltzmann noise of the resistive elements.

Sensing ranges of the APS00B can be easily extended by using multiple sensors, and component counts can be minimized by multiplexing sensor output signals to one or more analog to digital converter ICs. Multiplexing can also be utilized to reduce sensor power consumption in energy limited applications.

This AMR sensor is available in a small SOIC-8 package. These plastic encapsulated silicon sensor die are inherently insensitive to mechanical shock and vibration. A matching instrumentation amplifier APS00A is also available from Honeywell in SOIC-8 package shown in Figure 16.

**Figure 16. Honeywell SOIC-8 package**

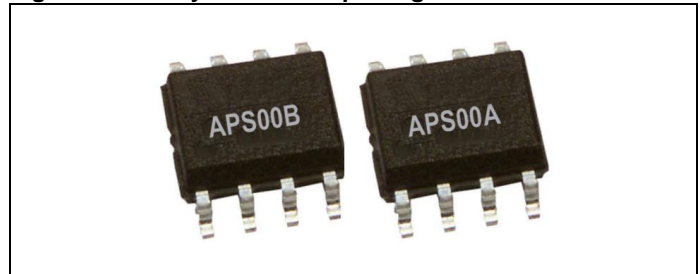

# How to Apply Honeywell APS00B Angular Position Sensor ICs

## **WARNING**

### **PERSONAL INJURY**

DO NOT USE these products as safety or emergency stop devices or in any other application where failure of the product could result in personal injury.

**Failure to comply with these instructions could result in death or serious injury.**

### **WARRANTY/REMEDY**

Honeywell warrants goods of its manufacture as being free of defective materials and faulty workmanship. Honeywell's standard product warranty applies unless agreed to otherwise by Honeywell in writing; please refer to your order acknowledgement or consult your local sales office for specific warranty details. If warranted goods are returned to Honeywell during the period of coverage, Honeywell will repair or replace, at its option, without charge those items it finds defective. **The foregoing is buyer's sole remedy and is in lieu of all other warranties, expressed or implied, including those of merchantability and fitness for a particular purpose. In no event shall Honeywell be liable for consequential, special, or indirect damages.**

While we provide application assistance personally, through our literature and the Honeywell web site, it is up to the customer to determine the suitability of the product in the application.

Specifications may change without notice. The information we supply is believed to be accurate and reliable as of this printing. However, we assume no responsibility for its use.

## **WARNING**

### **MISUSE OF DOCUMENTATION**

- The information presented in this application sheet is for reference only. Do not use this document as a product installation guide.
- Complete installation, operation, and maintenance information is provided in the instructions supplied with each product.

**Failure to comply with these instructions could result in death or serious injury.**

### **SALES AND SERVICE**

Honeywell serves its customers through a worldwide network of sales offices, representatives and distributors. For application assistance, current specifications, pricing or name of the nearest Authorized Distributor, contact your local sales office or:

**E-mail:** [info.sc@honeywell.com](mailto:info.sc@honeywell.com)

**Internet:** [www.honeywell.com/sensing](http://www.honeywell.com/sensing)

### **Phone and Fax:**

Asia Pacific	+65 6355-2828 +65 6445-3033 Fax
Europe	+44 (0) 1698 481481 +44 (0) 1698 481676 Fax
Latin America	+1-305-805-8188 +1-305-883-8257 Fax
USA/Canada	+1-800-537-6945 +1-815-235-6847 +1-815-235-6545 Fax

Sensing and Control  
Honeywell  
1985 Douglas Drive North  
Golden Valley, MN 55422  
[www.honeywell.com/sensing](http://www.honeywell.com/sensing)

005904-2-EN IL50 GLO Printed in USA  
August 2011  
Copyright © 2011 Honeywell International Inc. All rights reserved.

# Honeywell